

STAINLESS STEEL BALL VALVE

2 Pcs Design (Screwed)

Specification & Features:

Design Ref. BS: 5351

Two Pcs Design, Full Bore, Blow Out Proof Stem,
Floating Ball, PTFE Seats / Seals.

Quarter Turn Lever Operated.

Screwed Female Ends to BS 21 / ISO 7

Ideally suited for bi-directional, on/off duties for various
process industries.

The stainless steel construction enables the valve to handle a
wide range of corrosive media within Pressure / Temperature
rating of PTFE Seats.



ITEM CODE # SS - 802

Materials of Construction

NAME OF PART	MATERIAL	STANDARD
Body	Stainless Steel	ASTM A351 Gr. CF8 / CF8M
Body Connector	Stainless Steel	ASTM A351 Gr. CF8 / CF8M
Ball	Stainless Steel	ASTM A351 Gr. CF8 / CF8M
Stem	Stainless Steel	AISI 304 / 316
Gland Nut	Stainless Steel	AISI 304
Locking Nut	Stainless Steel	AISI 304
Lever	Stainless Steel	AISI 304 (PVC Coated)
Body Seal	PTFE	
Seat	PTFE	
Steam Packing	PTFE	

Testing : Standard EN 12266 – 1 (BS 6755 Part 1)

Description	Hydraulic	Steam
Test Pressure (bar)	69	10

Sizes / Dimensions

SIZES		DIMENSIONS (mm)		
Inch	mm	L	H	A
1/4"	8	60	50	100
3/8"	10	60	50	100
1/2"	15	62	50	100
3/4"	20	73	60	125
1"	25	85	60	150
1.1/2"	40	105	95	190
2"	50	125	100	190
2.1/2"	65	155	150	285
3"	80	180	170	285
4"	100	210	195	325

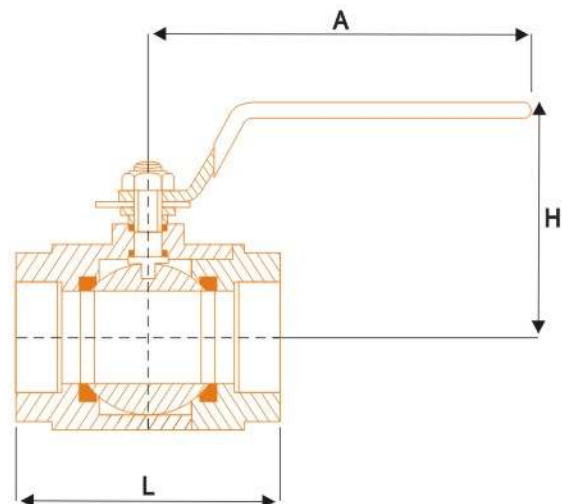

B.V.M. MANUFACTURERS & EXPORTERS

